

passion
for precision

fraisa

TopSolid[®]
BUILDING TRUST, SHAPING THE FUTURE.

Training guide

Import of cutting conditions from the Fraisa ToolExpert

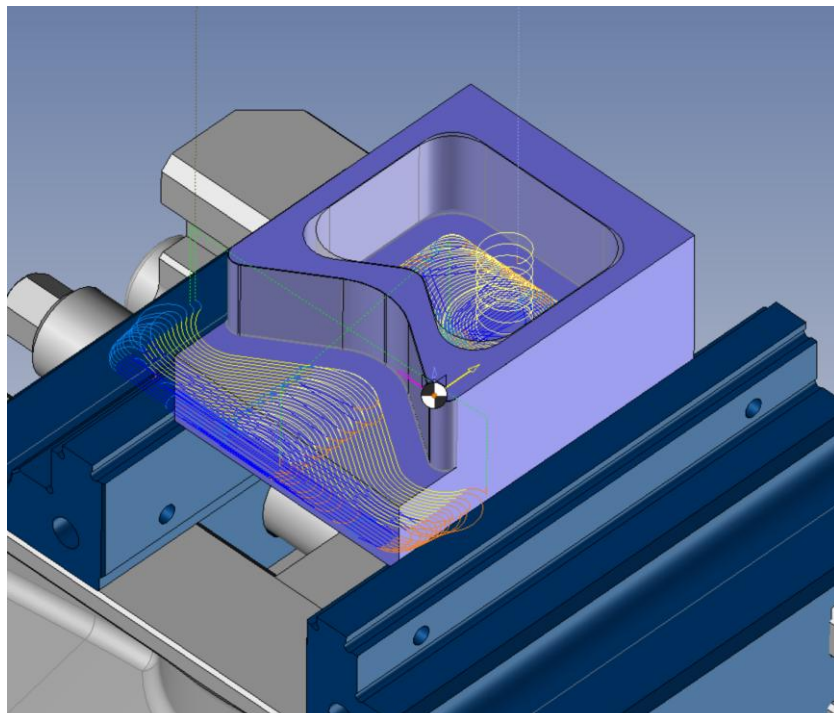

2026, **TOPSOLID SAS**.
7, Rue du Bois Sauvage
F-91055 Évry, FRANCE
Web: www.topsolid.com

All rights reserved.

TopSolid® is a registered trademark of **TOPSOLID SAS**.

TopSolid® is a product name of **TOPSOLID SAS**.

The information and the software contained within this document are subject to change without prior warning and should not be construed as a commitment by **TOPSOLID SAS**.

The software covered by this document is supplied under license and may only be used and duplicated in compliance with the terms of this license.

Hard copy or digital materials provided during training or accessible on-line as part of the training represent a protected original work that is the property of the training organization. They cannot be reproduced in part or in full without the express consent of the training organization.

All the texts, comments, works, illustrations and images reproduced on these materials are protected by copyright worldwide. Any use other than that designed for the purposes of training is subject to the prior authorization of the training organization, subject to prosecution. The Customer shall refrain from using, reproducing, representing,

lending, exchanging, transmitting or transferring and more generally exploiting all or part of the documents without the prior written consent of **TOPSOLID SAS**. The Customer shall also refrain from extracting all or part of the data and/or transferring it to another material, and from modifying, adapting, arranging or transforming it without the prior written consent of the training organization. The Customer is only granted a right of use, to the exclusion

of any transfer of ownership in any form whatsoever. Therefore, only the reproduction and representation of the content authorized by the French Intellectual Property code on a screen, and a single hard copy for archiving purposes, are authorized, for strictly personal purposes, and for professional use.

The Customer also undertakes to not take part in competing, directly or indirectly, with the training organization by transferring or communicating these documents to anyone.

Version 7.19

Rev. 04

Summary

Generalities	1
Requirement	1
Setting	2
1. Material identification	2
2. Tool identification.....	3
3. Cutting Diameter and number of tool teeth	4
Import of cutting conditions	5

Generalities

The Fraisa ToolExpert module allows you to import cutting conditions directly into TopSolid without having to search on internet or in the cutting tool catalogue.

This module is available from version 7.15 SP8 in TopSolid'Cam Standard Milling, Standard Turning, Pro Milling, Pro Milling-turning.

Requirement

In order to establish the link between TopSolid and the Fraisa ToolExpert, in the Tools/Options/CAM Options/Cutting conditions external/Fraisa tab, check the "Show ToolExpert button" box.

Then enter the download directory in « Download file name ».

This module is available in several languages. To define the desired language, in "ToolExpert culture identifier", enter en for English.

(English : en, French : fr, German : de, Italian : it, Hungarian : hu, Chinese : cn)

Finally, the computer used must have an Internet connection.

The links below are pre-defined in TopSolid:

ToolExpert start address :

<https://toolexpert.fraisa.com/api/topsolidcheck?company=topsolid&language=it>

Sending address of the API for ToolExpert :

<https://toolexpert.fraisa.com/api/topsolidcheck?{%NormIdentfier%}={%MaterialIdentifier%}&bestno={%ToolIdentifier%}&company=topsolid&language={%CultureIdentifier%}>

If you make a mistake, the 'Reset' button allows you to restore the default settings.

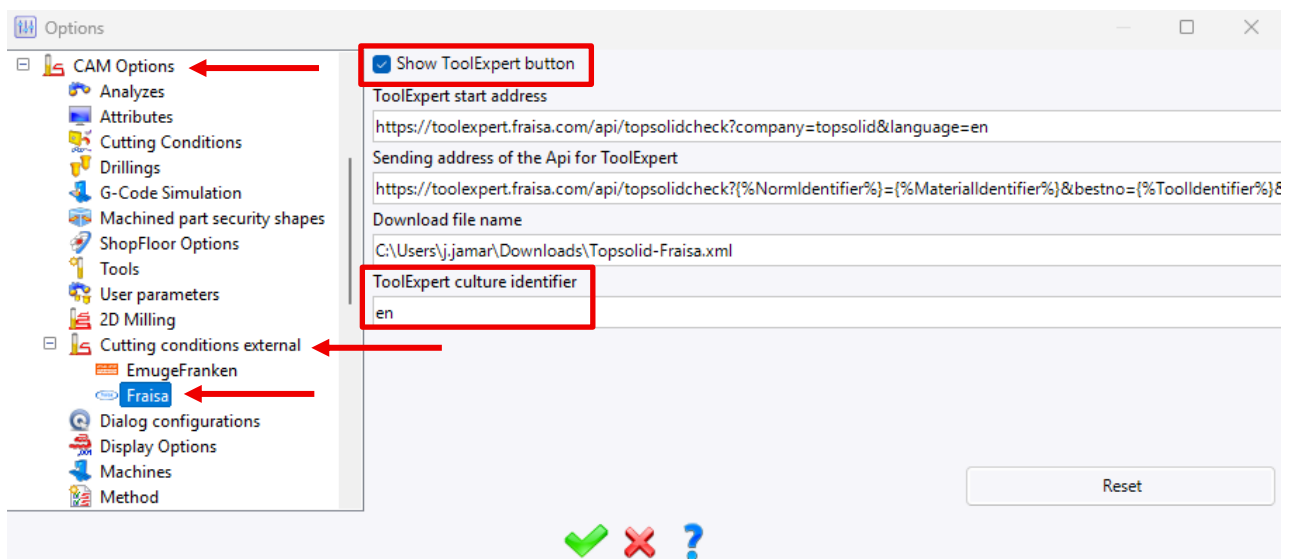

Setting

In order to import cutting conditions, you must first enter several pieces of information such as the material of the part to be machined, the reference of the cutting tool, its diameter and its number of teeth.

1. Material identification

In order for ToolExpert to automatically select the material of the part to be machined, the part must be associated with a material. The material document in TopSolid must be identified by a "Manufacturer Part Number".

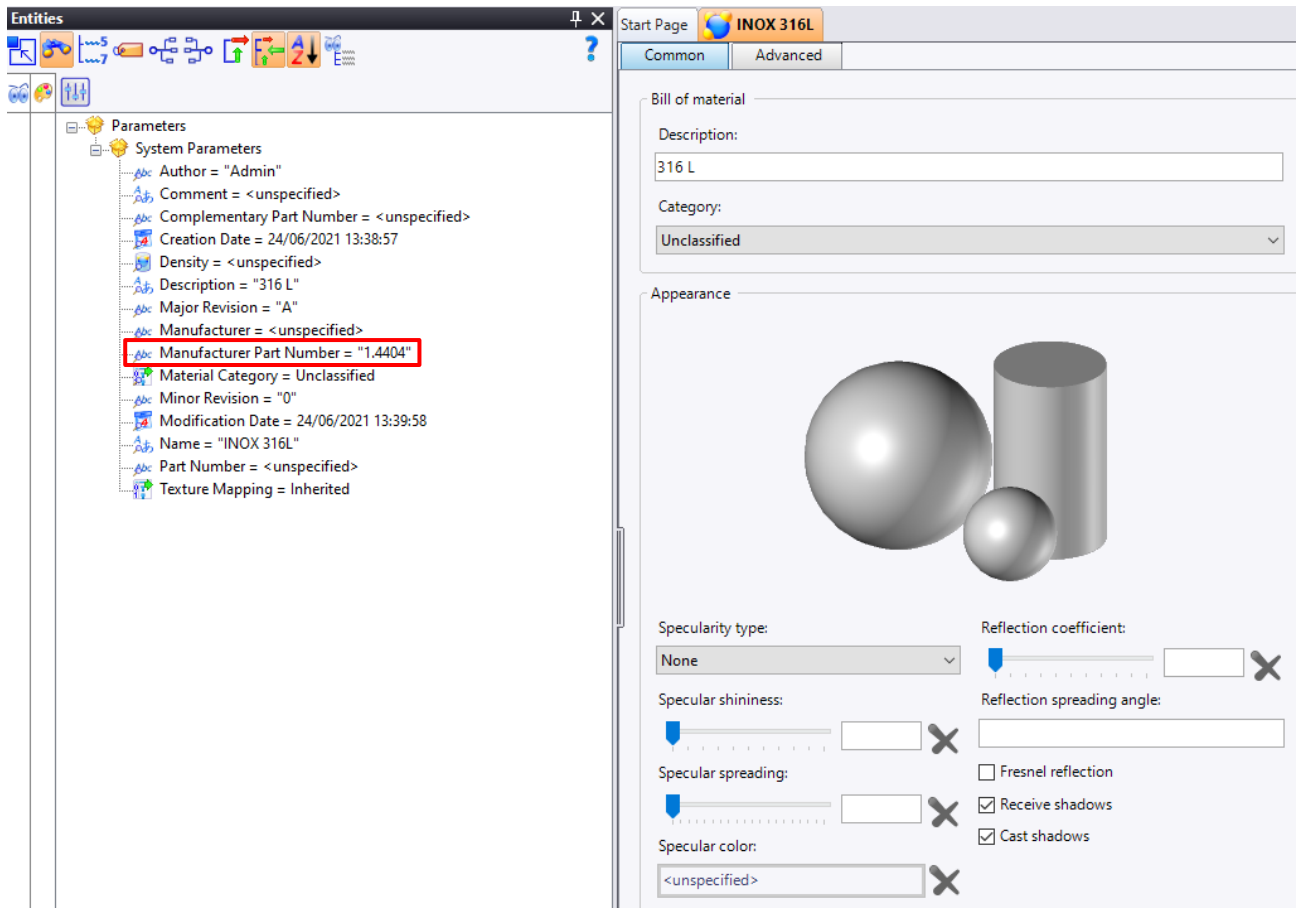

2. Tool identification

In the same way as for the material, the "Manufacturer Part Number" must be entered in the tool or the tool/toolholder assembly.

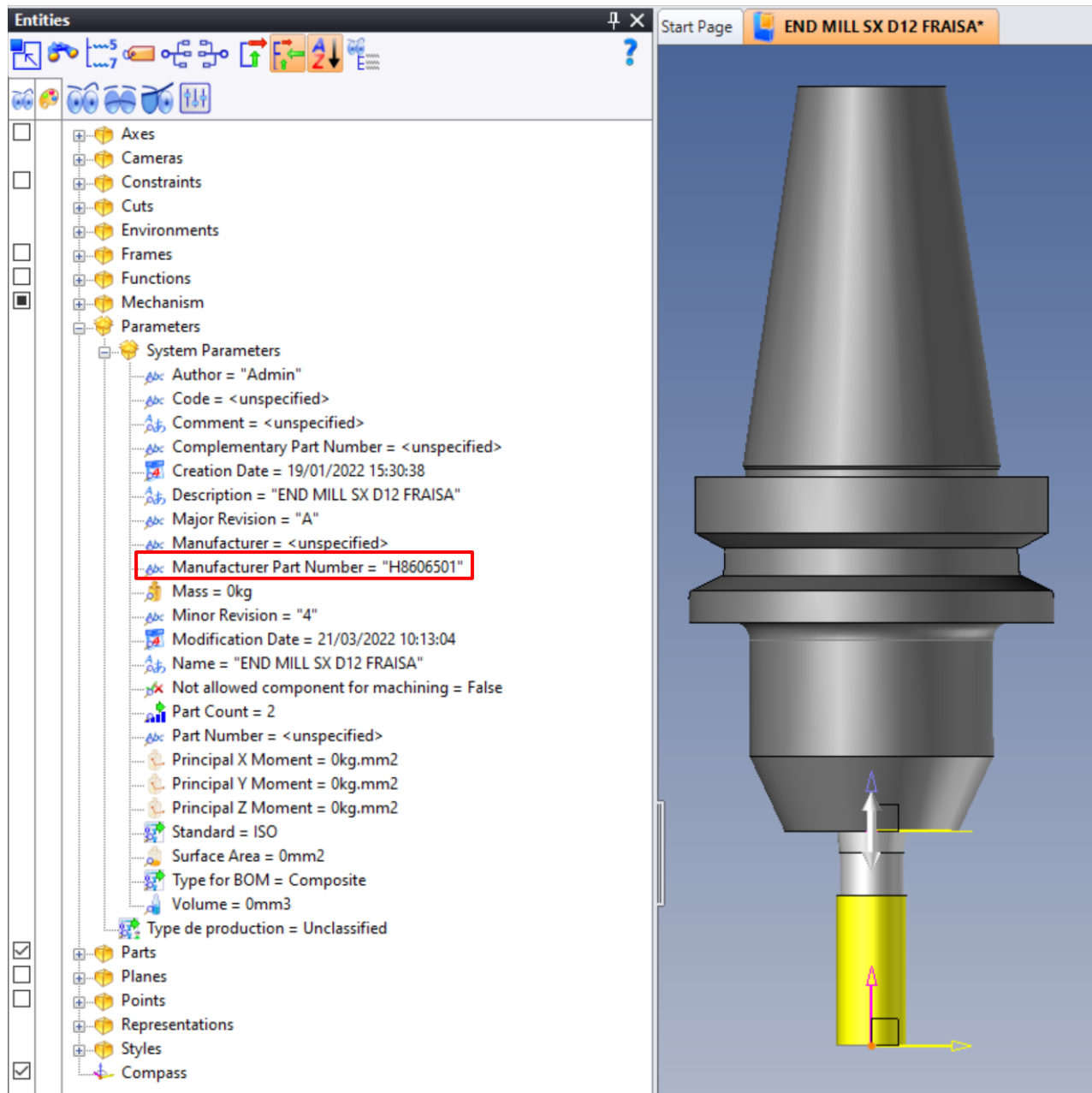

3. Cutting Diameter and number of tool teeth

This information is retrieved directly from the tool when it is created via the Tools/Functions/TopSolid'Cam Assistants/Machining component assistant tab.

The screenshot displays the 'Radiused Mill <Cutter_1>' configuration window. The 'Cutting Diameter' field is highlighted with a red box and contains the text 'D1=12mm'. Below it, the 'Number Of Tool Teeth' field is also highlighted with a red box and contains 'Z=4'. Other visible settings include 'Cutting Length: L2=26mm', 'Corner Radius: R=0,2mm', 'Cutting Tool Material Category: None', 'Left-Hand: M3', 'Coolant Nozzle: False', 'Maximum Ramp Angle: 0°', 'Center Cutting: False', and 'Cutting Edge Origin: Absolute Frame (SX C D12 H8506501)'. A 3D model of the tool is shown at the bottom left, and a vertical cross-section diagram of the tool is shown on the right.

Import of cutting conditions

In the milling operations, in the "Cutting conditions" tab, the Fraisa ToolExpert button is now visible.

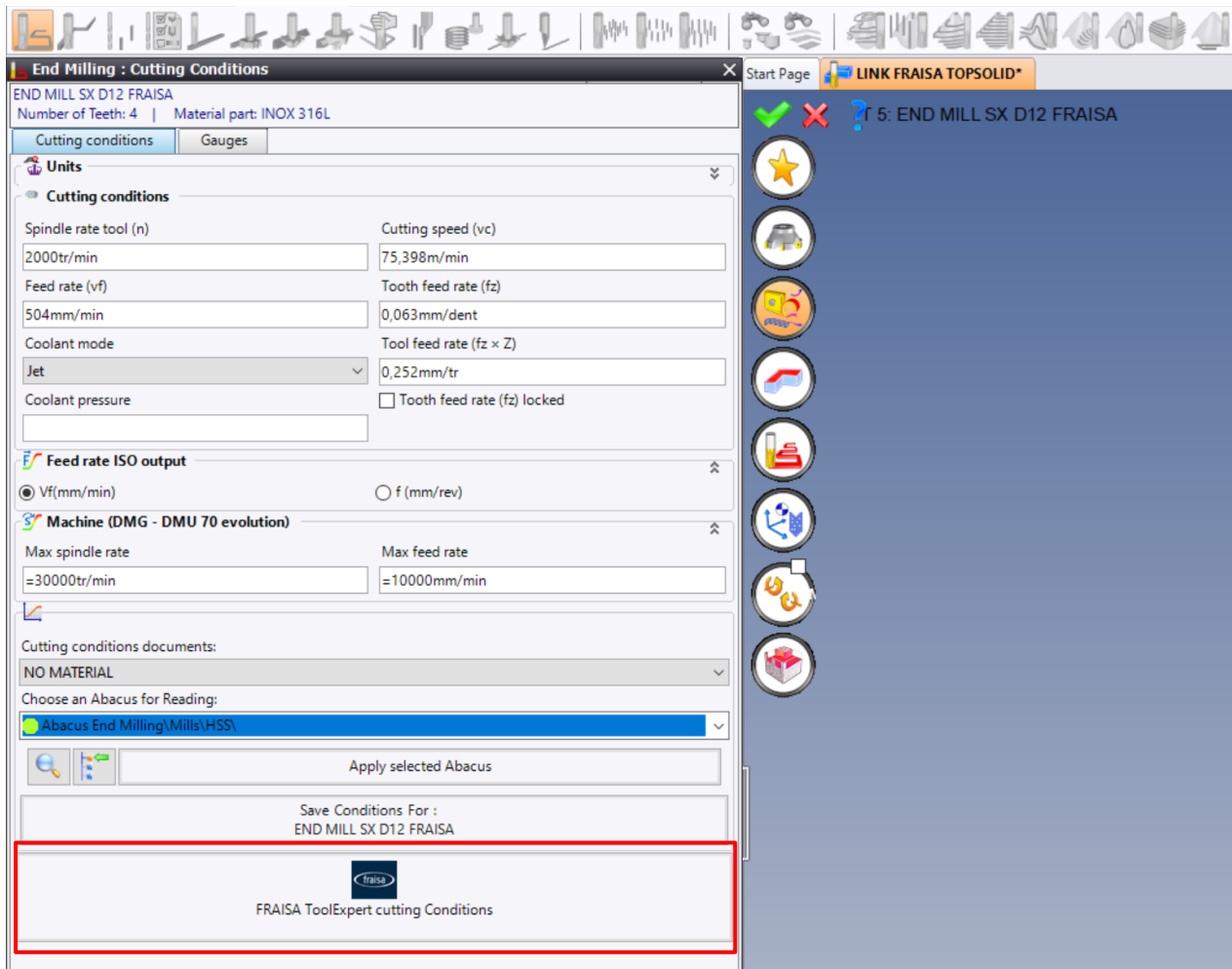

Clicking on this button opens a window containing the various information automatically retrieved by TopSolid, which is required to import cutting conditions.

Click on the "Send to ToolExpert" button to be redirected to it.

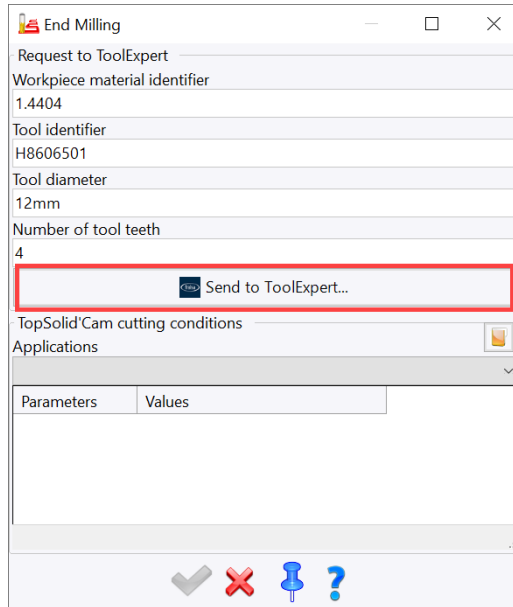

On ToolExpert, the material is pre-selected. If several variations of the material exist, the user must select one. Then you will reach the application selection page.

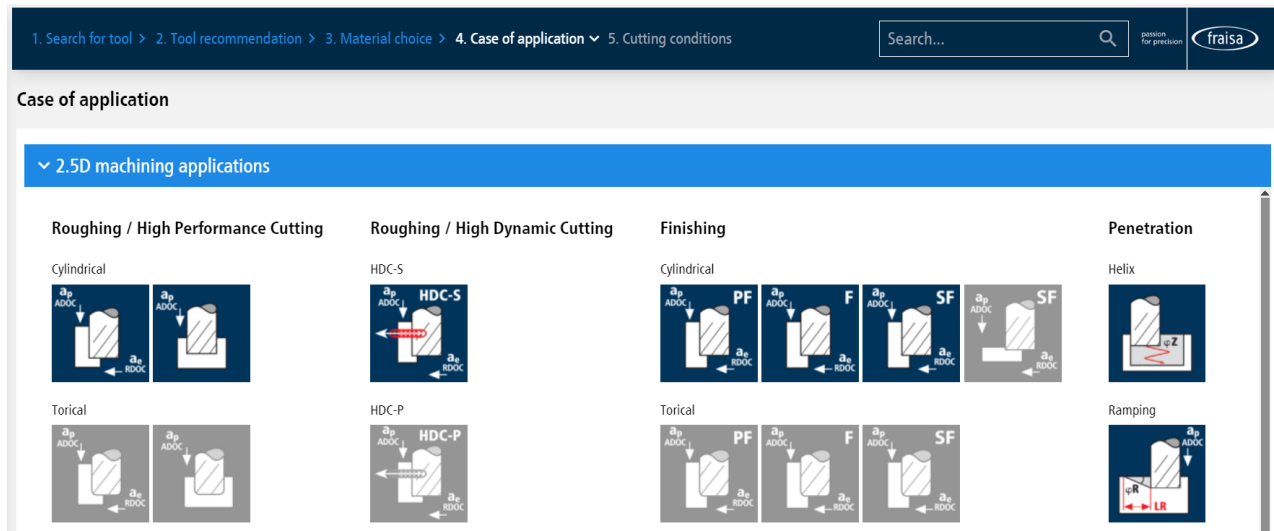

Select the application you are interested in and the ToolExpert will suggest cutting conditions that you can modify if necessary.

If you wish to import additional cutting conditions for the material penetration, which may be different, click on the "Add application" button.

Tool data



Order ref.	Diameter of the cutting edge	Length	Coating
H8606501	12 mm	normal version	DURO-Si

Description

Cylindrical/Square end mills SX
Smooth-edged, normal version, short neck

Actions

Add another application
Select another application for the tool and material you have already selected and add it.

+ Add application

+ Add all application

Add new application
Select a new application, material or tool and add the new application data to the application data you have already generated.

+ Add application

🛒 Buy product online

Cutting data



HDC-S

Emulsion / Oil
Excellent suitability

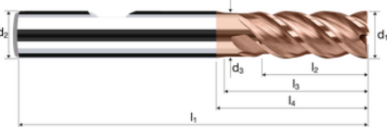

Selected material

PathStainless and heat-resisting steel \ Stainless st...	Material	1.4404	Norm	StNr
--	----------	--------	------	------

Recommended cutting data

Select your HDC application ⓘ

Low dynamics 10%

Medium dynamics 7.5%

High dynamics 5%

Diameter of the cutting edge	d1	[mm]	12
Number of cutting edges	z	-	4
Cutting speed	vc	[m/min]	147
Feed per tooth	fz	[mm]	0,198
Axial infeed depth	ap	[mm]	26
Radial infeed depth	ae	[mm]	0,9
Radial infeed depth	ae	[%]d ₁	7,5
Tool angle of action	ew	[°]	31,8
Spindle speed	n	[min ⁻¹]	3909
Feed rate	vf	[mm/min]	3103
Material removal rate	Q	[cm ³ /min]	72,62

< Back

Modify cutting data

The ToolExpert then asks you to select another application, so select the cutting conditions according to the type of material penetration.

To integrate the selected cutting conditions into TopSolid, click on "Download XML" and then on the "Back to TopSolid" button.

Cutting data

Emulsion / Oil
Excellent suitability

Downloads

[Download simulation file](#)

[Download DXF file](#)

[Download XML file](#)

Page 1 Page 2

[Download PDF file](#)

Selected material

PathStainless and heat-resisting steel \ Stainless st...	Material	1.4404	Norm	StNr
--	----------	--------	------	------

Recommended cutting data

Diameter of the cutting edge	d1	[mm]	12
Number of cutting edges	z	-	4
External diameter of the drilled hole	DA	[mm]	22.8
Diameter of the centering path	DZ	[mm]	10.8
Hole depth	TB	[mm]	26
Cutting speed	vc	[m/min]	80
Feed per tooth	fz	[mm]	0.054
Spindle speed	n	[min ⁻¹]	2122
Feed rate of the centering path	vfZ	[mm/min]	458
Penetration angle of the centering path	φZ	[°]	5

Download XML

Back to TopSolid

[Modify cutting data](#)

Note : Some browsers automatically block downloads. In order to be able to import the cutting conditions, the download of the XML file is mandatory, so you will have to allow/hold the download.

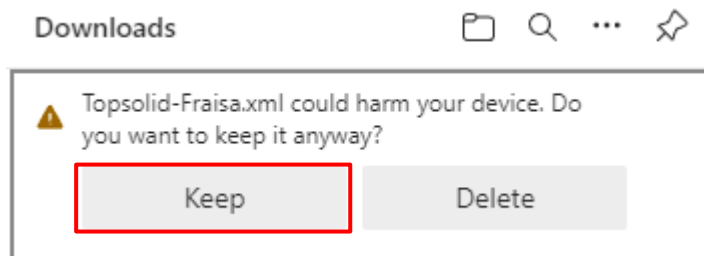

Back in TopSolid, we can see that the cutting conditions are now accessible in the "Applications" drop-down list.

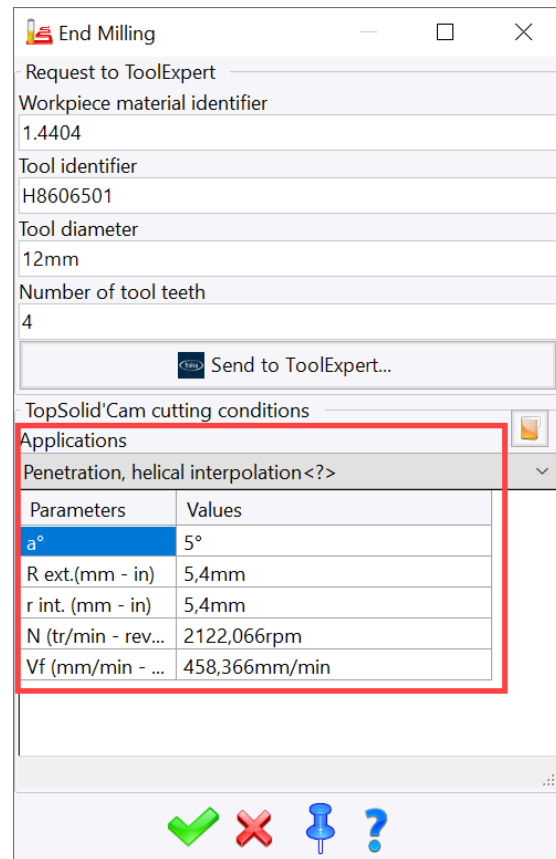
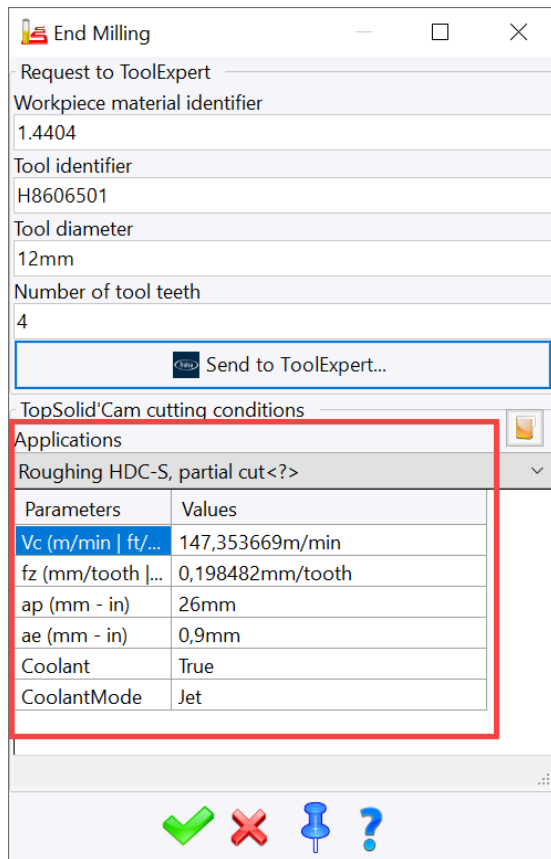

Simply validate to apply the cutting conditions to the tool and the operation settings.

Various parameters are imported:

- Cutting speed (Vc)
- Feed per tooth (fz)
- Spindle rate (N)
- Feed rate (Vf)

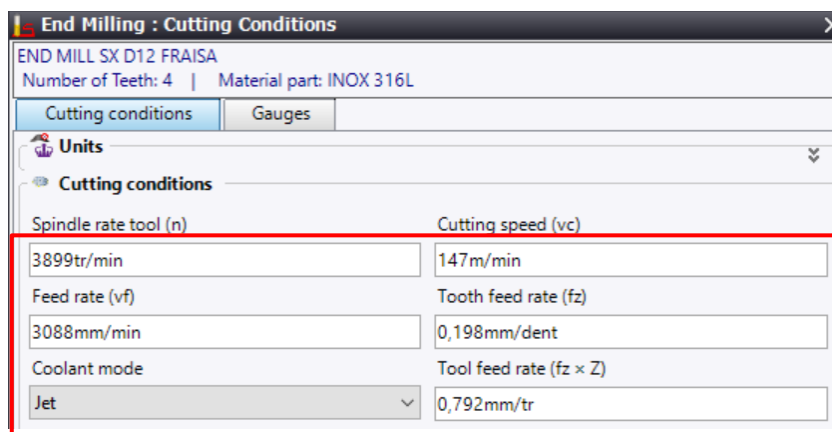

- Radial infeed depth (ae)
- Axial infeed depth (ap)

End Milling : Settings

Settings Altitudes

Plunge Retract Contouring integrated

Islands facing High Speed Machining Boost Collisions

Stock : 35mm Machined Stock + 0mm Stock Left = 35mm
 Passes : 2 x 17.5mm = 35mm

Machining profiles options

Take into account the stock shape Take into account the finish shape

Overlap

Step over / Step over (%) 0,9mm ≤ 7,5% External clearance distance 0,5mm

Steps

Axial path method Maximal axial depth of cut

Maximal axial depth 26mm Final axial feed rate F^* Machining = 3103.214mm/min

Final axial depth pass 0mm Final axial spindle rate S Tool Machining = 3908.677462rpm

Stocks to leave

Stock to leave on floor 0mm Stock to leave on wall 0,2mm

Stock to leave on wall island 0,2mm Stock to leave on Value 0mm

Organization of strategies

Order of the path Order by pockets

Strategy

Milling direction Climb

Z path stock fitting strategy None

End milling strategy Boost

Use the mixed milling direction

- Penetration strategy
- Radius of helix
- Penetration angle
- Custom penetration feed rate
- Custom penetration spindle rate

